

SHOREMASTER 650 LIFT ASSEMBLY INSTRUCTIONS

For assembly of your ShoreMaster lift, follow steps 1 - 11 with visual reference to the enclosed diagrams. A tape measure will be necessary to measure parts. For best operation, it is recommended that the lift be operated in at least 18" of water.

NOTE: If the lift is used on land with a boat on it (winter storage, display, etc.) the lifting portion of the lift should be in a partially raised position. If completely lowered, all the weight of the boat will be resting on the rear stop and damage may result. When in the water, the boat will be floating before this point is reached.

NOTE: Remove drain plug when the boat is out of the water.

NOTE: Only hand tighten bolts until your lift is completely assembled.

NOTE: IF YOU HAVE ANY FURTHER QUESTIONS, PLEASE CALL SHOREMASTER AT 1-800-328-8945.

STEP 1

Insert all (4) legs into the lift sides and bolt into place using 3/8" X 2 1/2" bolts. Then set the lift sides about 7' apart.

STEP 2

Bolt the front bottom beam (53" piece) to the lift sides using 3/8" X 4 1/2" bolts. (See Diagram 2)

STEP 3

Bolt the I-beams to the lift sides using 1/2" X 3 1/2" bolts. *NOTE* A 1/2" washer should be placed between the I-beams and the lift sides and between the I-beams and the 1/2" locking nuts to assure free movement. Do not over-tighten locking nuts. (See Diagrams 2 and 3)

STEP 4

Bolt the (2) rack sides (54 1/2" pieces) to the insides of the I-beams using 1/2" X 3 1/2" bolts. *NOTE* A 1/2" washer should be placed between the I-beams and the rack sides and between the rack sides and the 1/2" locking nuts to assure free movement. Do not over-tighten locking nuts. (See Diagrams 2 and 3)

STEP 5

Bolt the front and rear rack planks (47 1/2" pieces) to the top of the rack sides using 3/8" X 3 1/2" bolts. *NOTE* Before doing this however, slide (2) 650 fixed cradle brackets on the front and (2) on the rear rack plank. Make sure the set screws are facing towards the middle of the lift. *NOTE* Do not put the (2) bolts that are closest to the winch end or the front of the lift in at this time. (See Diagrams 2 and 3)

STEP 6

Attach the (2) pulleys with 3-link chains by putting the last link inside the front ends of the rack sides and by inserting the last (2) 3/8" X 3 1/2" thru the rack plank, the chain link and the rack side. (See Diagrams 2 and 3)

STEP 7

Attach the (1) pulley with 2-link chain and a upright extension (17 1/2" piece) to the lift side that the winch will go by using a 3/8" X 4" U-bolt and washers. (See Diagram 2)

STEP 8

Attach (1) end of the lift cable and the other upright extension (17 1/2" piece) by using a 3/8" X 4" U-bolt with washers and (2) cable clamps. (See Diagram 2)

STEP 9

Attach the winch to the lift upright using 3/8" X 2 3/4" bolts and washers. Then attach the cable to the winch spool using the rope clamp to secure it. (See Diagram 2)

STEP 10

Attach the lift braces to the bottom beam using 3/8" X 2 1/4" bolts and to the lift uprights using 3/8" X 2 3/4" bolts with washers. (See Diagram 2)

STEP 11

Put (2) blue caps on top of the lift uprights and (2) blue caps on top of the rear legs. * IMPORTANT * PLEASE BE SURE TO PUT THE BLUE CAPS ON THE REAR LEGS TO PROTECT YOUR PERSONAL WATER CRAFT FROM BEING SCRATCHED OR DAMAGED!!

PARTS LIST FOR SHOREMASTER 650 LIFT

<u>QUANTITY</u>	<u>DESCRIPTION</u>
2	LIFT SIDES
2	I-BEAMS
1	FRONT BOTTOM BEAM (53" PIECE OF ALUMINUM TUBING)
2	RACK SIDE BEAMS (54 1/2" PIECES OF ALUMINUM TUBING)
2	RACK PLANK BEAMS (47 1/2" PIECES OF ALUMINUM TUBING)
2	LIFT SIDE EXTENSIONS (17 1/2" PIECE OF ALUMINUM TUBING)
4	650 FIXED CRADLE BRACKETS
4	LIFT LEGS
2	LIFT BRACES

SHOREMASTER 650 HARDWARE LIST

<u>QUANTITY</u>	<u>DESCRIPTION</u>
8	1/2" X 3 1/2" MACHINE BOLTS (I-BEAMS)
2	3/8" X 4 1/2" MACHINE BOLTS (BOTTOM BEAM)
8	3/8" X 2 1/2" MACHINE BOLTS (LEGS & CRADLE BRACKETS)
8	3/8" X 3 1/2" MACHINE BOLTS (FRONT & REAR RACK PLANK)
4	3/8" X 2 3/4" MACHINE BOLTS (WINCH & BRACES)
2	3/8" X 2 1/4" MACHINE BOLTS (BRACES)
8	1/2" LOCKING NUTS
28	3/8" NUTS
16	1/2" WASHERS
10	3/8" WASHERS
2	3/16" CABLE CLAMPS

1	B 1202 D.L. WINCH W/ HANDLE
1	D.L. WINCH KIT
3	PLASTIC PULLEYS
2	3/16" 3-LINK CHAIN
1	3/16" 2-LINK CHAIN
2	3/8" X 4" U-BOLTS
1	3/16" X 16' CABLE
2	#6 BLUE CAPS
2	#3 BLUE CAPS
1	INSTRUCTION SHEET

650 PARTS LIST DIAGRAM

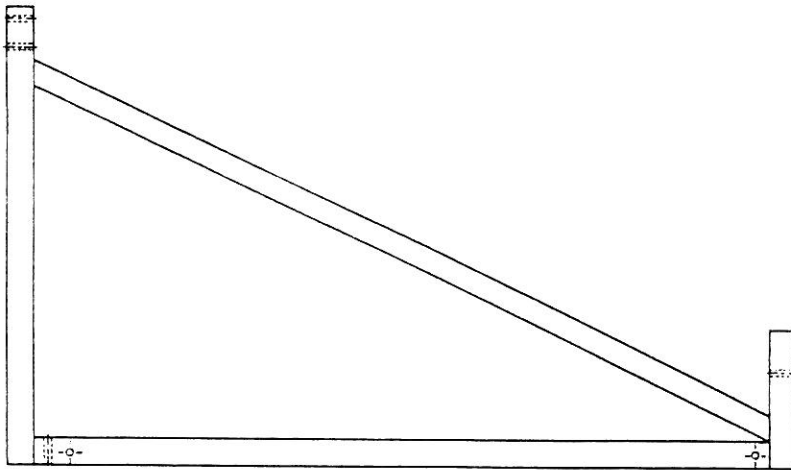

- LIFT SIDE

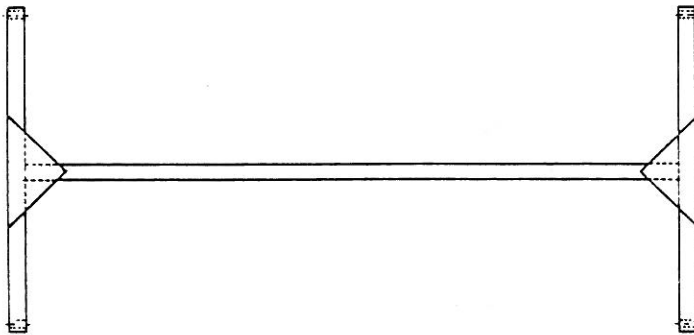

- I-BEAM

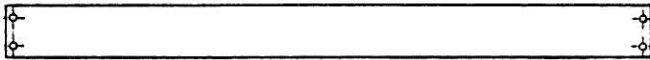

- RACK PLANK BEAM (47 1/2" long)

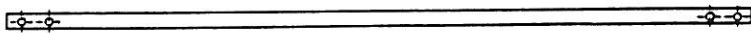

- RACK SIDE BEAM (54 1/2" long)

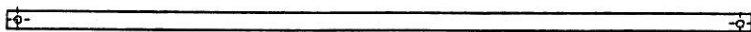

- FRONT BOTTOM BEAM (53" long)



LIFT SIDE EXTENSION
(17 1/2" long)

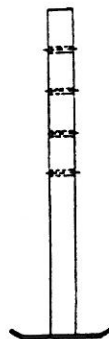

- LIFT LEG



- LIFT BRACE

DIAGRAM 2 - 650 LIFT (ASSEMBLED)

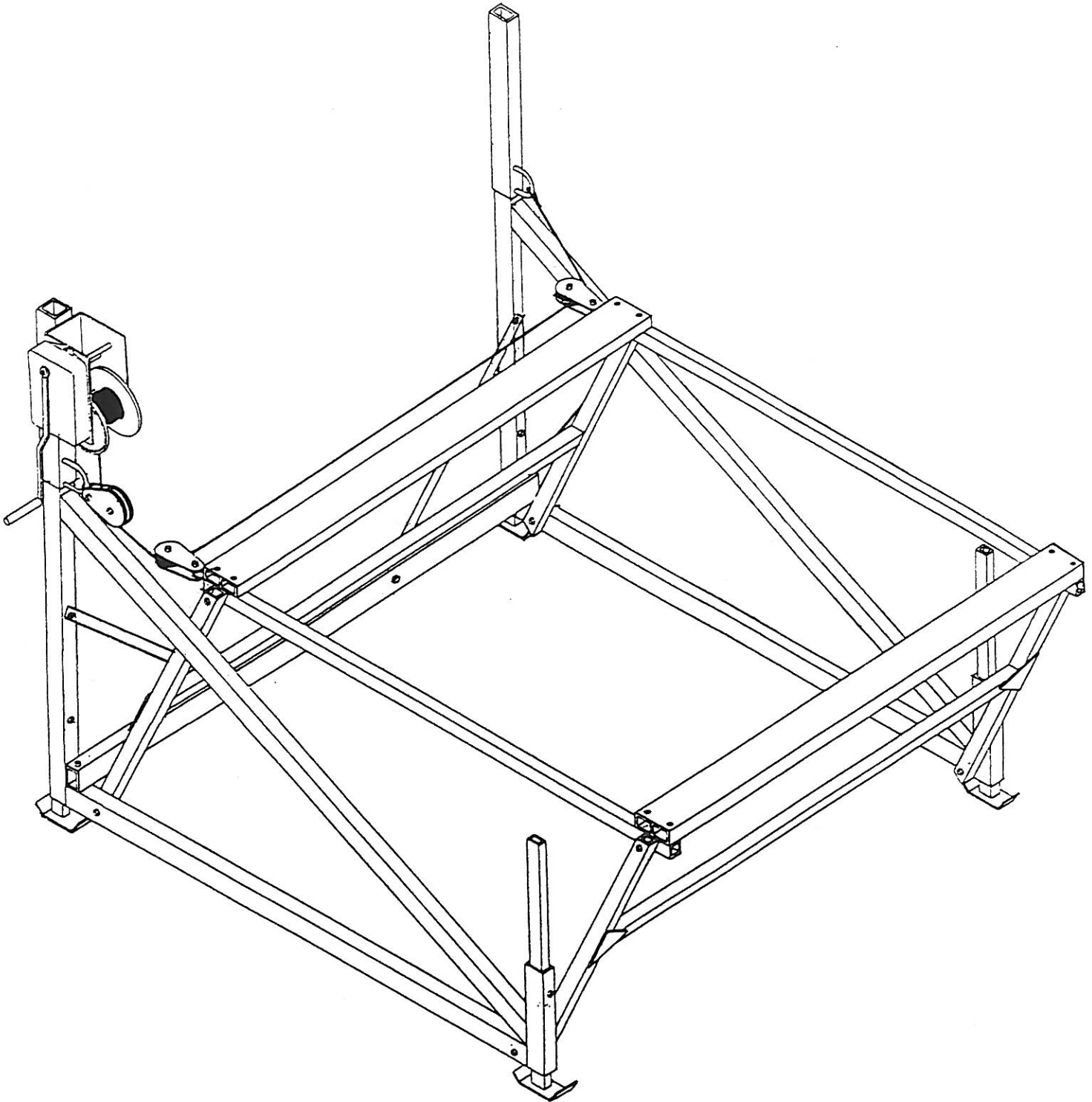
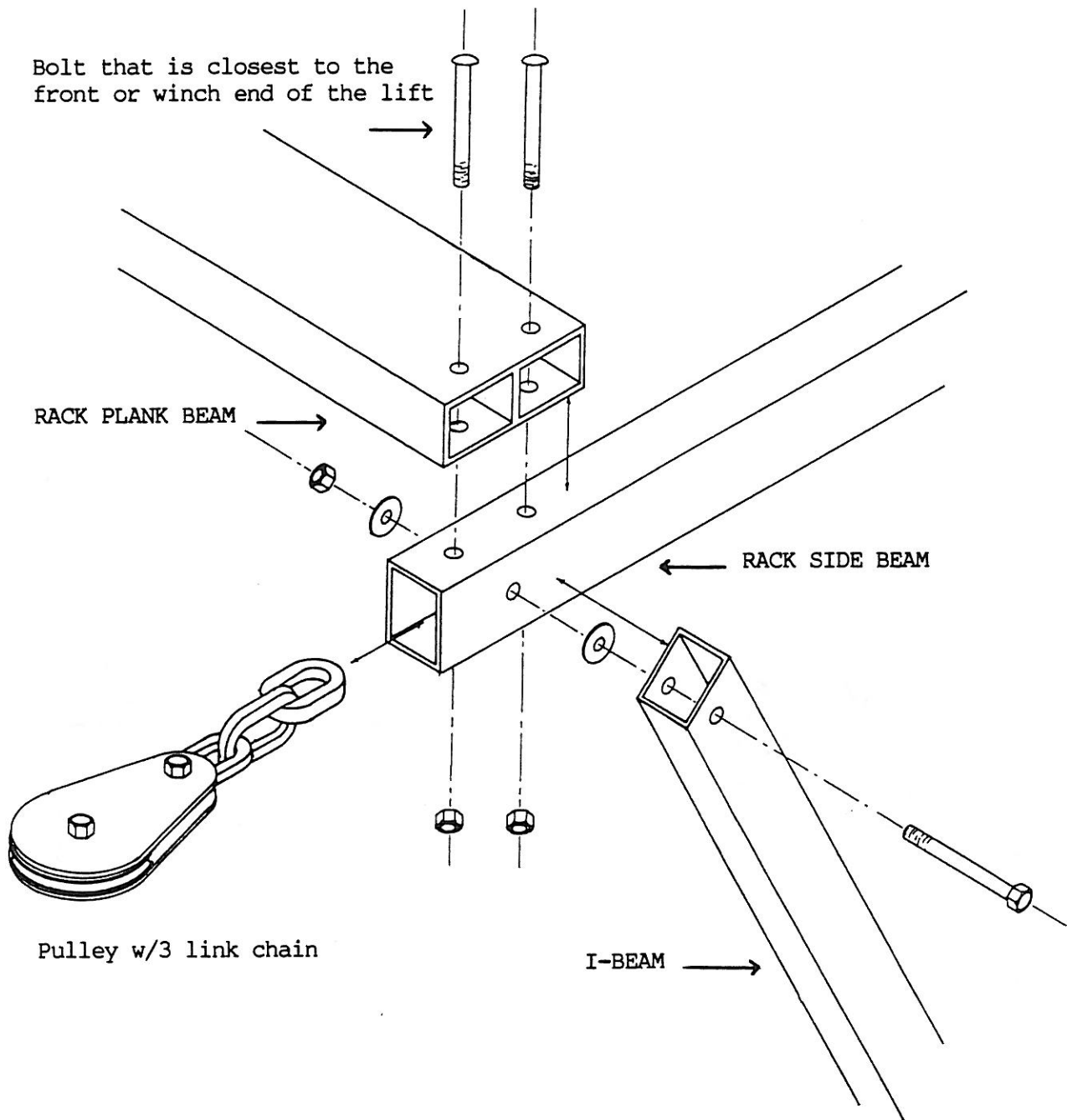

DIAGRAM 3

**** NOTE ****

Follow the same procedure on the other side of the lift.



600# FIXED CRADLE BRACKETS

- (1) Before attaching the front & rear rack planks, make sure the fixed cradles have been slid in place on the rack planks with the set screws facing the center of the lift.
- (2) Once the fixed cradles are place, snug them down using the set screws to secure them to the rack planks.
- (3) Put your wood in the fixed cradle and use the holes in the fixed cradle as pilot holes to drill through the wood. Then bolt the wood in place using 3/8" X 2 1/2" machine bolts.

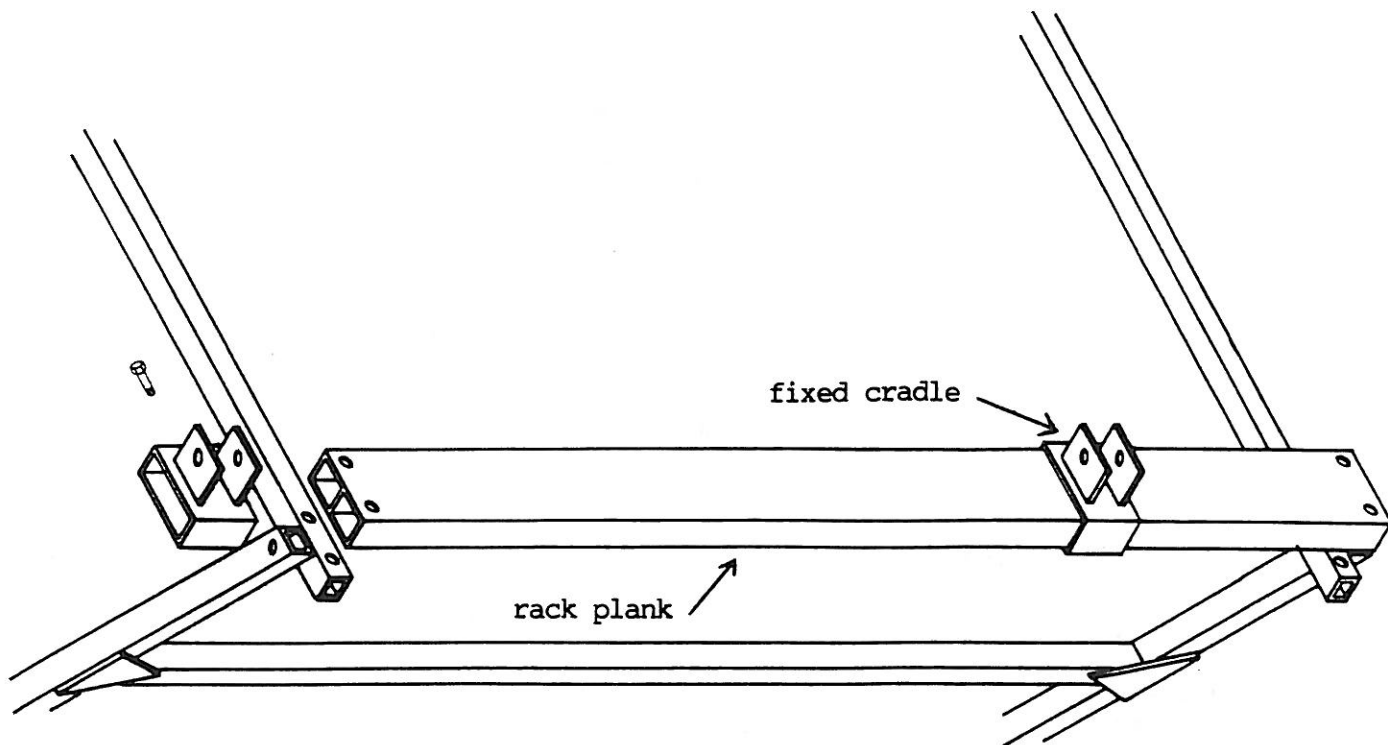

WINCH INSTRUCTIONS, SAFETY & MAINTENANCE

WINCH INSTRUCTIONS

Thread the wheel (or handle) on to the drive shaft turning clockwise until a clicking sound is heard and the rack begins to raise. Making sure the wheel (or handle) remains in firm contact with the brake pads and ratchet gear install the wheel kit to prevent the wheel (or handle) from backing off the winch driveshaft (step 6). Wind cable on winch hub being sure that it raps uniformly to prevent fraying or binding.

Wind cable off the hub by turning counter-clockwise (no noise will be produced). The wheel (or handle) will then remain in position when the wheel (or handle) is released. Sufficient load must be applied to lift for brake mechanism to activate properly, otherwise turning the wheel (or handle) will only remove the wheel (or handle) from the shaft. Always satisfy yourself that the winch brake is holding the load before releasing the wheel (or handle). If it is not, rapid spin down could occur. DO NOT attempt to stop wheel (or handle) if this should happen.

If at anytime the wheel (or handle) turns down with great difficulty, the brake may not have released. The brake pads may be worn or not smooth enough to allow brake to release. It is important that the wheel (or handle) and shaft threads are greased periodically. DO NOT, however, grease any part of the brake mechanism.

* IMPORTANT *

NEVER wind cable off the winch hub so that excess slack occurs in the cable. Excess slack in the cable could allow the cable to slip off the winch hub or pulleys and cause damage to your lift or winch and may cause personal injury.

SAFETY

The winch for this lift is strickly for lifting operations. It is not to be used as a method of supporting or transporting people, or for loads over areas where people may be present.

Check winch for proper operations on each use. If it is damaged in anyway do not attempt to operate.

Never allow children or those unfamiliar with the operation of the lift to use it.

Never exceed recommended lift capacity. Personal injury may result.

Never apply load to winch with cable fully extended. There should be at least four full turns of cable on the hub.

WINCH MAINTENANCE

It is recommended that the winch be inspected periodically (twice yearly). Necessary preventive maintenance is required for maximum performance of the winch.

1. Remove all of load from the lift until cable BEGINS to slack. Remove wheel kit and wheel (or handle) from shaft.

2. Remove clutch plates and ratchet gear from shaft. Sand off any rust or corrosion on these parts. DO NOT grease the clutch mechanism.

3. Replace clutch plates and ratchet gear on the shaft. One clutch plate should be on each side of the ratchet gear. Replace wheel (or handle) and wheel kit.

4. Check to be sure that ratchet pawl and spring are aligned on the ratchet gear. You can do this by turning the wheel (or handle) clockwise. A clicking sound should be heard. If it is not functioning properly, check to see that your spring is in place. There must be tension in the springs for pawl to ratchet properly.

5. Check to see that gears, shafts and chains are attached and turning freely. Grease all bearings and gear teeth with good wheel bearing grease.

6. Replace winch cover. Check mounting of winch to be sure that it is secure and properly aligned. Also, check cable to make sure it is secure and there is no abnormal stiffness or broken strands.

7. Replace any worn or broken parts with authorized ShoreMaster parts available at your local dealer or ShoreMaster.

**** DO NOT ATTEMPT TO OPERATE LIFT WITHOUT FIRST STUDYING THE FOLLOWING ****

OPERATING & SAFETY

1. After assembly (and yearly), check to be sure that all nuts and bolts are tightened as required. Check pulley sheaves, cable, winch, and lift rack to see that they are all operating freely.
2. Make all possible adjustments to lift legs, cradles, EPU's, and other accessories before installing lift in the water. Adjusting lift parts while in the water is more difficult and potentially more dangerous. NEVER make any adjustments with the boat in the lift.
3. Test to see that the winch is working properly by winding up cable on hub by turning the wheel (or handle) clockwise. The winch should be making a clicking sound. A brake will activate automatically when you stop, allowing you safe and controllable use.
4. ***** IF AT ANYTIME THE WHEEL (OR HANDLE) SPINS UNCONTROLLABLY DO NOT ATTEMPT TO STOP IT !! *****
5. Never attempt to operate lift unless winch is functioning properly. **IMPORTANT: **IT IS RECOMMENDED THAT ANYONE OPERATING THE LIFT FIRST THOROUGHLY STUDY THE OWNERS MANUAL.** Study winch maintenance, instructions, and safety tips located in your owners manual.
6. Never allow rack to be in a fully lowered position with the boat in it (winter storage etc.). Damage may result to the rack (this applies to cantilever models only).
7. Be sure that the boat is properly balanced and centered on the lift before attempting to raise the rack. Generally, the boat should be as far forward in lift as possible for proper balance.
8. It is recommended that the lift be operated in at least (3) feet of water. This will allow for easier raising of the wheel (or handle) and less strain on the winch (cantilever models only).
9. Do not raise the rack past the recommended height (over center on a cantilever). Doing so could damage the lift or cause the winch or cable to break.
10. DO NOT turn the wheel (or handle) counter-clockwise to the point where the cable begins to develop slack. Doing so may allow the cable to jump the spool and cause personal injury and damage to the winch.
11. If at anytime there is more than the normal resistance when operating the wheel (or handle) and winch, do not attempt to force it. Lower the lift and check for possible problems with winch or other lift parts.

12. NEVER exceed the recommended weight capacity of the lift. Doing so could result in personal injury or irreparable damage to the lift. Also, it would invalidate the lift's warranty.
13. Pull drain plug from boat when not in use. Failing to do so may result in water accumulating and the load exceeding recommended lift capacity.
14. Lock your wheel (or handle) and rack in place by chain and padlock when unattended. This will help prevent theft or possible spin down of wheel and rack.
15. Check cable and pulleys for any signs of wear or failure. If this is the case, replace them immediately.
16. Never allow anyone (especially children) on or around lift when in a raised position or when being raised or lowered.

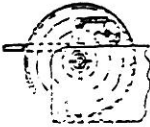
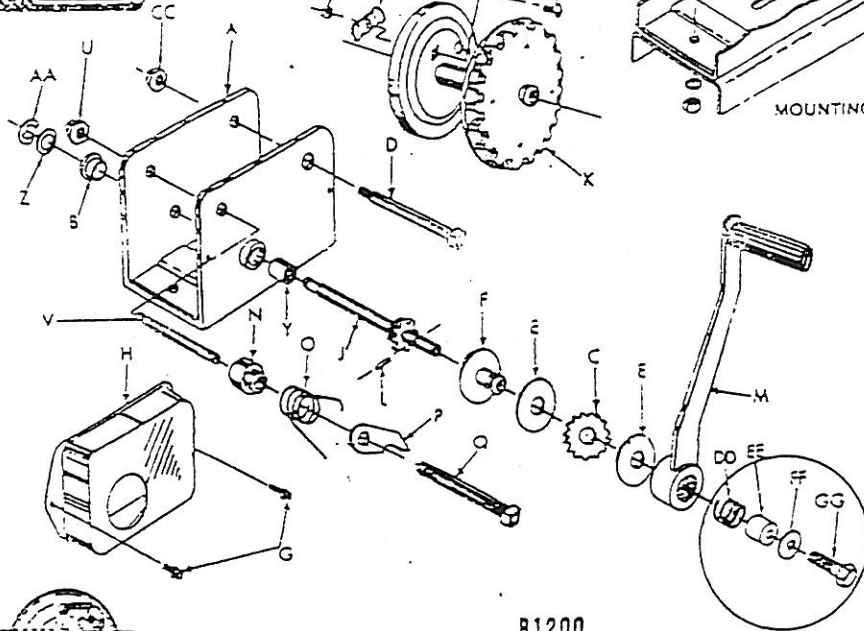

CABLE ATTACHMENT

81200

GEAR RATIO - 4:1
LOAD CAPACITY - 1200 LBS.
REEL CAPACITY - 7/32" DIA. CABLE, 58 FT.

PARTS PRICE SHEET
B-1200 WINCH

<u>REF. LETTER</u>	<u>PART NAME</u>
A	WINCH BASE ASSEMBLY
B	OILITE BEARING
C	RATCHET WHEEL
D	REEL BOLT
E	BRAKE LINERS (FIBER CLUTCH)
F	BRAKE WINCH HUB ASSEMBLY
G	SELF TAPPING SCREW (EACH)
H	GEAR COVER
J	DRIVE SHAFT ASSEMBLY
K	REEL ASSEMBLY 1-1/8" HUB
KA	REEL ASSEMBLY 2-1/2" HUB
L	ROLL PIN
M	WINCH HANDLE ASSEMBLY
N	RATCHET PAWL SPACER BUSHING
O	BRAKE RATCHET SPRING
P	RATCHET PAWL
Q	RATCHET PAWL BOLT
R	CARRIAGE BOLT
S	1/4" HEX NUT
T	ROPE CLAMP
U	3/8" LOCKNUT (EACH)
V	SPACER SLEEVE
Y	9/16" NEEDLE BEARING
Z	SPACER WASHER
AA	RETAINER RING
DD	SPRING
EE	SHAFT EXTENSION
FF	RETAINER WASHER
GG	HEX BOLT